



**Pyramid AC Receiver  
Installation Manual**

---

**IMPORTANT**

The first few pages of these instructions contain important information on safety and product conformity. Please read, and ensure that you understand this information before continuing.

---

---

**CONTENTS**

<b>Product Safety</b> .....	4
<b>Electromagnetic Compatibility (EMC)</b> .....	4
<b>Manufacturer’s Declaration of Conformance</b> .....	4
<b>Unpacking</b> .....	4
<b>Barcoding</b> .....	4
The AC Receiver .....	5
PCB Layout .....	6
PCB Power Connections .....	7
Connecting the Preset Feedback Potentiometers .....	7
Connecting the Lens Drive Outputs .....	8
Connecting the Pan/Tilt Head and Auxiliaries .....	8
Connecting the Pan/Tilt Head and Auxiliaries Power Source .....	9
Anti-Tamper Connections .....	9
Video Connections .....	9
Fitting Network Cards .....	10
PY-FTT, PY-485 and PY-422 Network Cards .....	11
PY-COM Network Cards .....	12
Fibre-Optic Network Cards .....	12
Power Supply Connections .....	13
Addressing a Receiver with the Pyramid 2 Keyboard .....	14
Addressing a Receiver with the Mk1 Keyboard .....	15
Setting Receiver Configuration with the Pyramid 2 Keyboard .....	16
Setting Receiver Configuration with the Mk1 Keyboard .....	17
Receiver Programming .....	17
Testing .....	18
Replacing the Lid .....	18
Changing the Fuse .....	18
Specifications .....	19

---

**PRODUCT SAFETY**

---

**⚠ WARNING**

- Please follow these instructions as you install the equipment and keep them for future use.
- Installation is only to be carried out by competent, qualified and experienced personnel in accordance with the country of installation's National Wiring Regulations. Failure to do so can result in injury or death by electric shock.
- Use a class 2 isolated power supply for the 12V DC.
- The module is susceptible to damage from Electrostatic Discharge (ESD). Take normal ESD precautions when handling your network card. ESD prevention kits are available from most electronics distributors.
- Do not exceed the voltage and temperature limits given in the specification.
- Switch off the power before fitting a network card.
- If you have any problems, contact Baxall Limited.

---

**ELECTROMAGNETIC COMPATIBILITY (EMC)**

---

**⚠ CAUTION**

- This is a Class A product. In a domestic environment this product may cause radio interference in which case the user may be required to take adequate measures.
- This product is intended for use in general purpose CCTV applications in a residential, commercial or light industrial EMC environment. Refer to Baxall Limited before using the product in medical and/or intrinsically safe applications or in an industrial EMC environment.
- If you are using the PCB version of this product in a way other than correctly installed in the Pyramid system weatherproof boxes, then it is your responsibility to meet EMC requirements.
- The product must be installed in accordance with good installation practice for EMC to enable the product to function as intended and to prevent EMC problems.
- Contact Baxall Technical Support to obtain a specification defining the acceptable levels of product degradation with regard to EMC immunity.

---

**MANUFACTURER'S DECLARATION OF CONFORMANCE**

---

**⚠ CAUTION**

The declaration of conformance applies only to the boxed version and PCBs which are correctly installed in our Pyramid system weatherproof box.

The manufacturer declares that the equipment supplied with this manual is compliant with the essential protection requirements of the EMC directive 89/336 and the Low Voltage Directive LVD 73/23 EEC. Conforming to the requirements of standards EN55022 for emissions, IEC801 parts 2, 3 and 4 for immunity and BS415 superseded by EN60950 for Electrical Equipment safety.

---

**UNPACKING**

---

Keep your packaging for use if your AC receiver is stored for an extended period or needs to be returned for any reason. The packaging should contain:-

- An AC Receiver
- An A4 Module Description Sheet (for installation details)
- These instructions
- Two identical barcodes

Check the product code on the serial number label. If you have an incorrect item or it is damaged then inform the suppliers and carriers immediately. If this is the case, do not attempt to use the equipment.

---

**BARCODING**

---

The AC receiver is supplied with two identical barcodes. Remove one and affix it to the module description sheet, remove the other and affix it to the module.

The barcode gives the unique 48-bit neuron ID to the module. This neuron ID is also stored inside the module and will be transmitted onto the network whenever the PCB service pin is pressed. Before installation, make a careful note on your module description sheet of all your installation details and the proposed location of the module. Then during subsequent installation using the Windows™ installation tool the neuron ID can be entered.

We recommend that during a system installation you store the module description sheets in a ring-bound file, and keep them for reference after the installation is complete.

THE AC RECEIVER

The Pyramid AC Receiver is a fixed speed pan and tilt control receiver that can be connected to any camera within the Pyramid system that has an AC Pan/Tilt head. The receiver is easy to install, and a service pin and test button are included to aid the installation process. Once it has been fitted, the receiver will drive the pan, tilt, zoom and focus functions of a Pan/Tilt head, and it can also drive auxiliary equipment (wipers, lights etc.) through the four auxiliary relays on the receiver PCB.

The AC receiver can be programmed remotely with privacy zones, limit stops, random patrols, and up to 128 presets. It also contains a video amplifier, with gain and high-frequency lift. This can improve video transmission over longer cable runs.

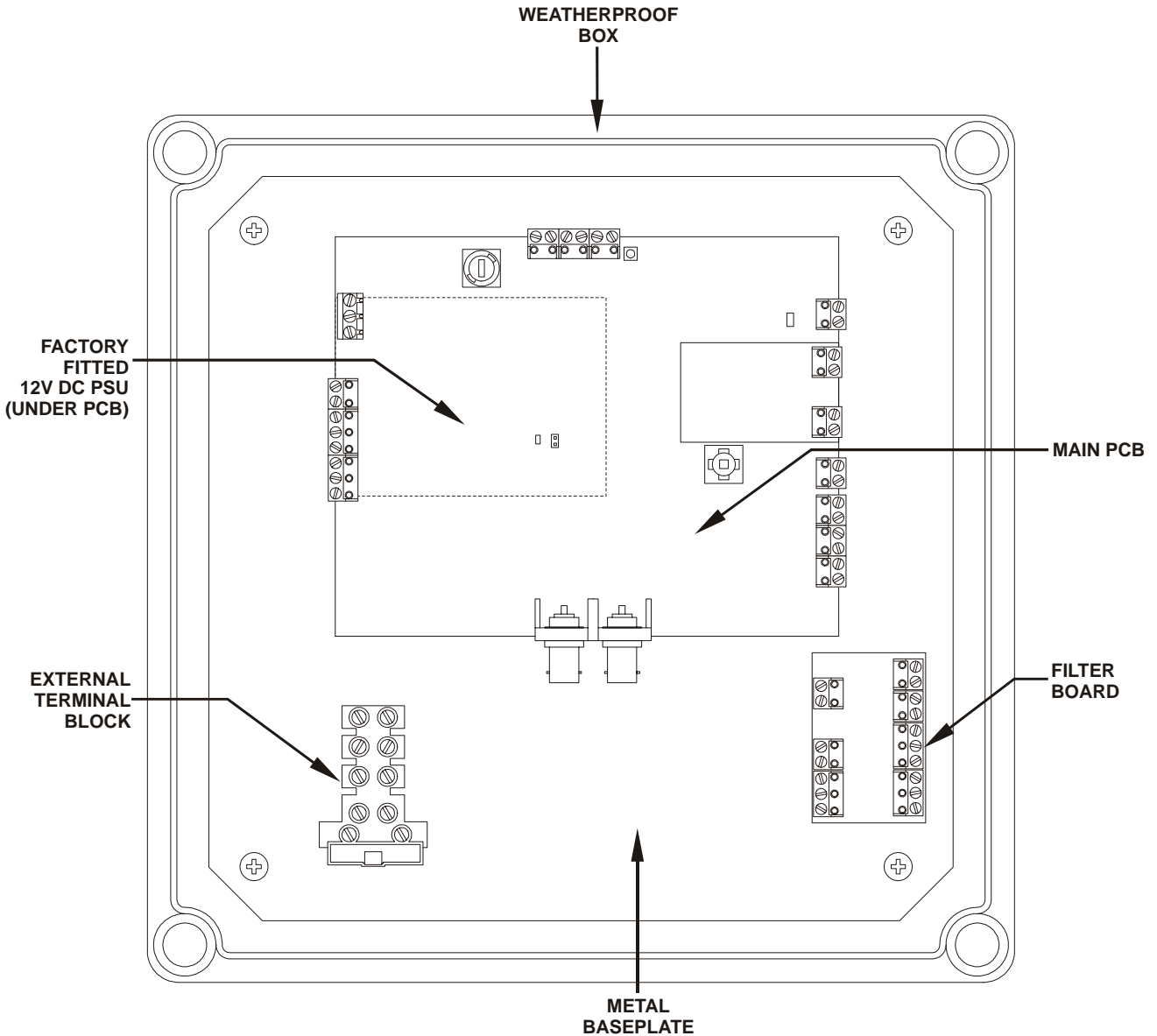

Figure 1 - AC Receiver Layout (Weatherproof Box Variants)

There are six variants of the AC receiver, which can be split into two groups—the three variants that are supplied in a weatherproof box (PY-ACW-) and the three variants that are supplied as a PCB only (PY-ACB-). In each of these two groups, the difference between the three variants is based on the network speed and the type of network card fitted.

The -L variants (PY-ACW-L and PY-ACB-L) run on a low speed (9.8k b.p.s.) RS485 network while the -HR variants (PY-ACW-HR and PY-ACB-HR) run on a high speed (78k b.p.s.) RS485 network. Both the -L and -HR variants are fitted with a PY-COM network card—a combined personality network card which can be configured by means of dip switches for use in RS485 or RS422 networks. By default, the switches are set so that the card operates in RS485 protocol, but the card protocol can be easily changed using the switch settings. For more details on the PY-COM network card, see page 12.

The -H variants (PY-ACW-H and PY-ACB-H) are fitted with a PY-FTT network card and run on a high speed (78k b.p.s.) FTT10 network. For more details on the PY-FTT network card, see page 11.

Shown below are the locations of the connectors, switches and LEDs on the AC receiver PCB.

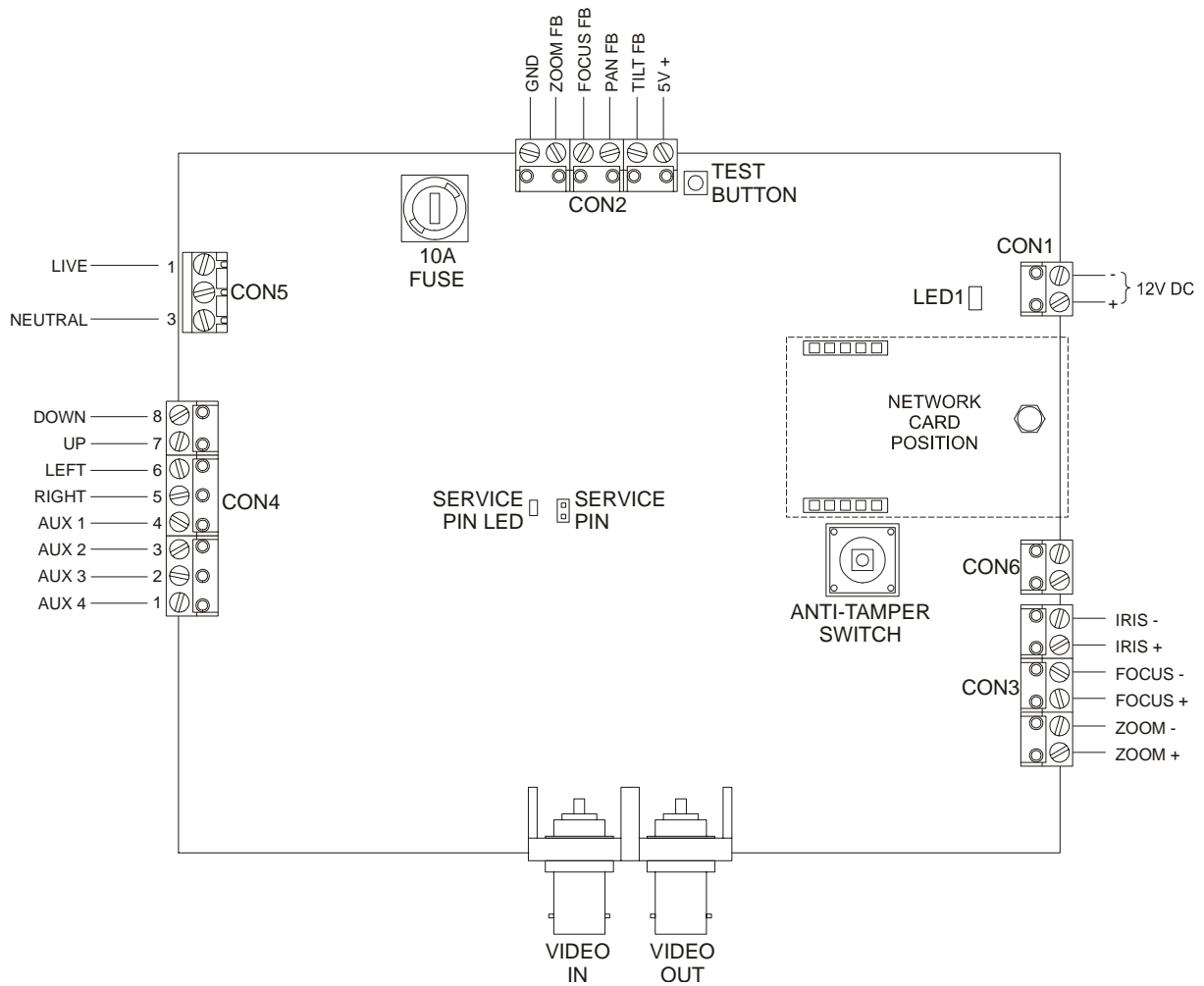

Figure 2 - AC Receiver PCB

PCB POWER CONNECTIONS

CON1 is used for PCB power connection. This power controls the switching of the relays, the video gain and lift and the lens functions. The AC power for the Pan/Tilt head and auxiliaries is connected separately to CON5.

The PCB requires a +12V DC, 1A class 2 power supply. The necessary connections have already been made on the boxed variants, including a grounding wire which is connected from the negative terminal of CON1 to the external terminal block (Figure 3). On PCB versions, connect the 12V DC as shown in Figure 3.

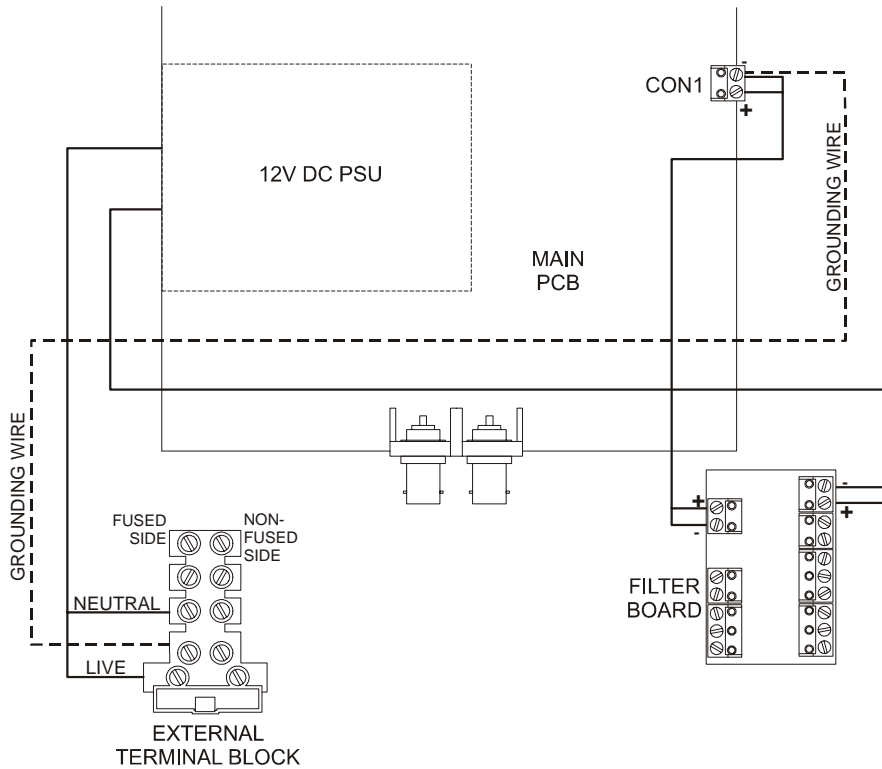

Figure 3 - PCB Power Connections

CONNECTING THE PRESET FEEDBACK POTENTIOMETERS

If you are using a preset Pan/Tilt head and lens, then CON2 provides the supplies and feedback connections for the potentiometer wiper circuits. The direction of the feedback is automatically calculated when the test routine is invoked (see **Testing** on page 18), this means it is not necessary to wire the pots in a specific direction.

Referring to Figure 4, connect CON2 to the preset pots on the Pan/Tilt head and the lens. Connect any unused feedback inputs to ground. Make a note on your module description sheet of the preset connections and the type of lens.

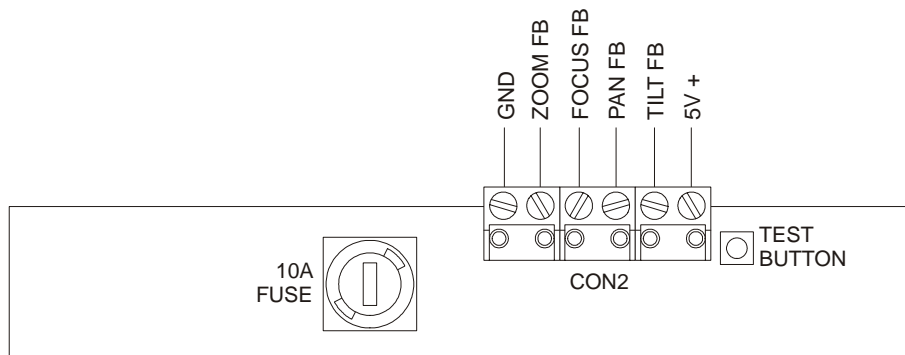

Figure 4 - CON2 Connections

**△ CAUTION**

The maximum power that can be drawn from the +5V supply on CON2 is 30mA. DO NOT use this supply for any purpose other than for supplying feedback pots.

**CONNECTING THE LENS DRIVE OUTPUTS**

CON3 provides the lens drive outputs for focus, iris and zoom. The drive voltage is +10V DC at up to 100 mA. Refer to your lens instructions and connect up the lens according to Figure 5.

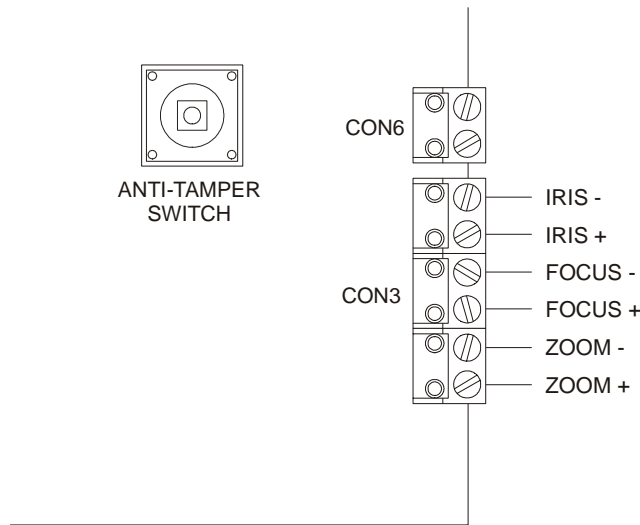

**Figure 5 - CON3 Connections**

**CONNECTING THE PAN/TILT HEAD AND AUXILIARIES**

CON4 contains the power output connections for the Pan/Tilt head and auxiliaries (AUX 1, AUX 2, AUX 3 and AUX 4).

Referring to Figure 6, connect LEFT, RIGHT, UP and DOWN to the Pan/Tilt head and AUX 1 to wash, AUX 2 to wipe, AUX 3 to lamps and AUX 4 to camera power. Do not connect any unused auxiliaries. Connect all the return (neutral) wires to the spare terminals on the external terminal block. Make a note on your module description sheet of your auxiliary connections.

**△ CAUTION**

**Maximum current is 1A per relay. Connect lamps using a separate relay as they can draw a surge current when they fail. This may cause damage to the AC receiver.**

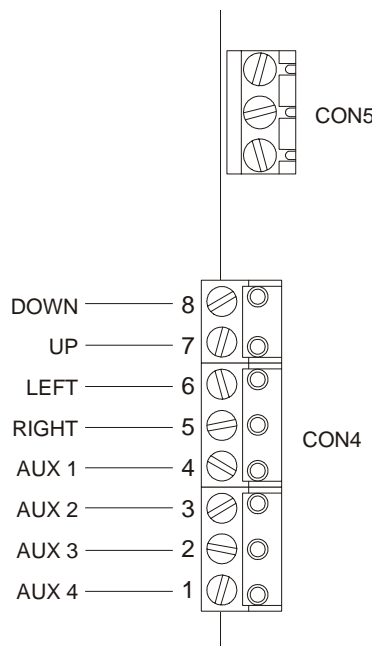

**Figure 6 - CON4 Connections**



---

**CONNECTING THE PAN/TILT HEAD AND AUXILIARIES POWER SOURCE**

---

CON5 accepts the AC power input which is then switched to CON4. It powers the Pan/Tilt head and auxiliaries. CON5 can be connected to either a 24V AC or Mains power supply.

**For Mains Connections**

Referring to Figure 7, connect CON5 to the LIVE and NEUTRAL connections on the external terminal block. The connections should be made to the non-fused side of the terminal block. The centre connection on CON5 is not connected.

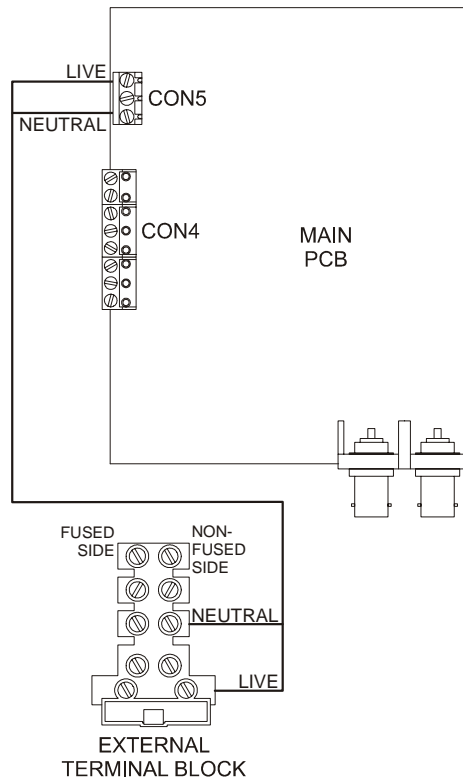

**Figure 7 - Connecting CON5 to a Mains Power Supply**

**For 24V AC Connections**

Connect the 24V AC power supply to the LIVE and NEUTRAL terminals on CON5 (see Figure 7 above). The centre terminal on CON5 is Not Connected (NC).

**⚠ WARNING**

**Never use both 24V AC and Mains on the same receiver PCB.**

---

**ANTI-TAMPER CONNECTIONS**

---

CON6 is used as an input for an external anti-tamper switch. It is connected in parallel with the built in anti-tamper switch that is marked in Figure 2.

On the boxed variants, the built in anti-tamper switch is connected in a normally open (N/O) configuration. However, it is fitted with a spring which is compressed when the module lid is closed, and thus closing the contact. When the lid is removed, the input is opened and the alarm will be activated.

If the built in anti-tamper switch is not used, CON6 can be connected to an external anti-tamper switch. To do this, the spring must be removed from the built in anti-tamper switch. CON6 should then be connected to the external anti-tamper switch in a normally closed (N/C) configuration.

---

**VIDEO CONNECTIONS**

---

All video must be connected to the receiver PCB via 75 ohm BNC connectors and video coaxial cable. Referring to Figure 2, connect the video from your camera to VIDEO IN and connect VIDEO OUT to the matrix.

Your AC receiver has an on-board video amplifier with gain and lift. Adjustment of gain and lift is done remotely, using a Pyramid keyboard. For more details on adjusting gain and lift levels, consult the **Pyramid 2 Keyboard Operating Manual**.

**FITTING NETWORK CARDS**

To connect the AC receiver to the network, it is first necessary to ensure that the correct Pyramid network card is fitted to the PCB. The cards that can be used are as follows:

- PY-COM** Combined network card. Can be configured for use in RS485 and RS422 networks. Automatic baud-rate selection between low and high speeds (9.8k b.p.s. or 78k b.p.s.).
- PY-FTT** Compatible with FTT10 (Flexible Topology) 2-wire bus-connected, half duplex. High speed only.
- PY-422** Compatible with RS422, 4-wire point-to-point, full duplex. Available in low and high speed variants.
- PY-485** Compatible with RS485, 2-wire bus-connected, half duplex. Available in low and high speed variants.
- PY-FI7 and PY-FI9** Compatible with dual, multi-mode fibre optic point-to-point connections. PY-FI7 operates at 78k b.p.s., PY-FI9 operates at 9.8k b.p.s.

If the correct network card is not already fitted, change it using Figure 8 as a guide.

**△ CAUTION**

To avoid damaging the module, switch off the power before fitting the network card.

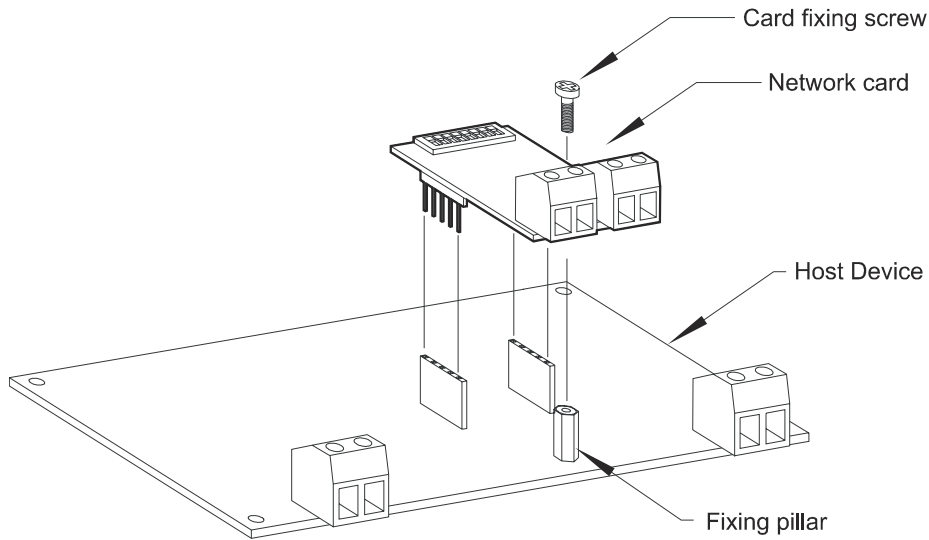

**Figure 8 - Fitting a Network Card**

Once a network card has been fitted, it must be connected to the network. The way in which this is done depends on the type of network card in use. See the following sections for more details.

PY-FTT, PY-485 AND PY-422 NETWORK CARDS

To connect PY-485, PY-FTT and PY-422 network cards to the network, it is necessary to make two connections. Firstly, the network card is connected to the filter board using the four-core screen cable provided. Secondly, the filter board is connected to the network.

Use Figure 9 below to connect PY-485 or PY-FTT network cards to the network.

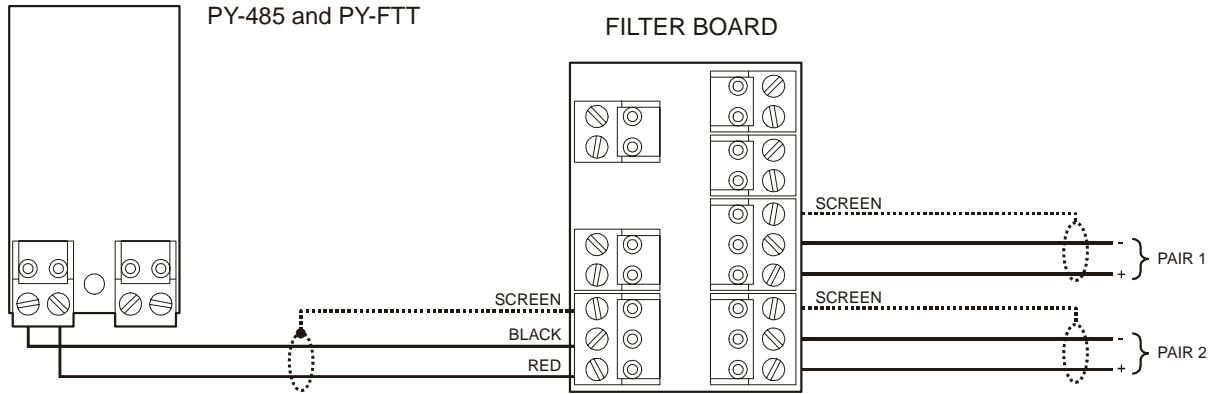

Figure 9 - PY-485 and PY-FTT Connections

Use Figure 10 to connect PY-422 network cards to the network.

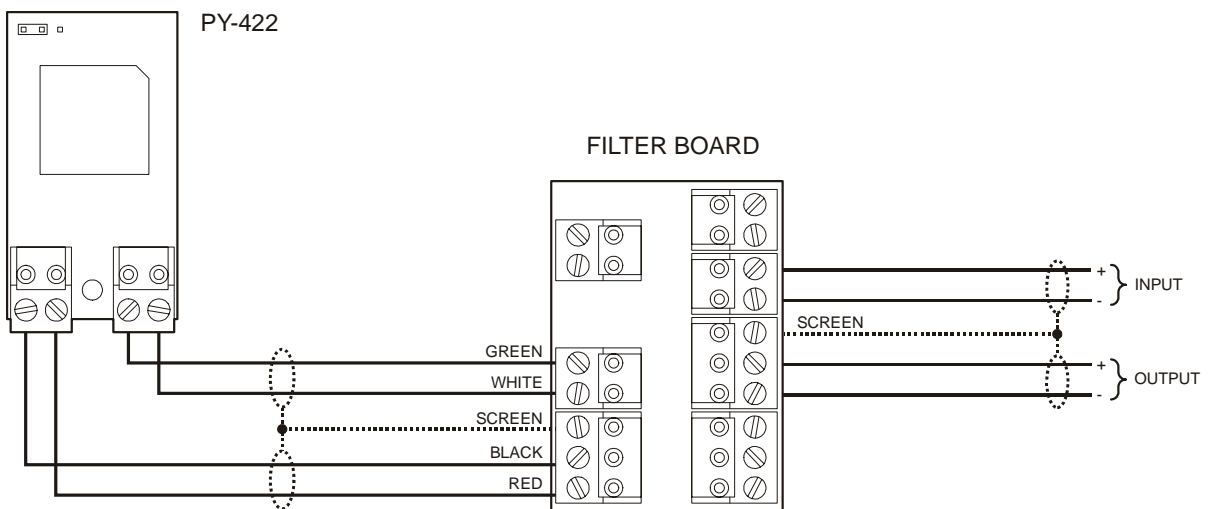

Figure 10 - PY-422 Connections

**PY-COM NETWORK CARDS**

If a PY-COM network card is fitted to the AC receiver, it can be configured by means of dip switches for use in both RS485 and RS422 networks. The dip switches for the different network types are shown below:

**RS485 Mode**

RS485 networks are 2-wire, bus-connected (also referred to as 'daisy-chain'). In RS485 mode, the dip-switches on the PY-COM will be set differently depending on where the unit is placed on the network. If the unit is the first or last in the network, one network card in the unit will need to be set to provide biasing and termination as required. If the unit is central to the network, all network cards will be set for use in a intermediate module.

Set the switches as required and wire the card to the network as shown in Figure 11. It is not necessary to make any connections to the filter board.

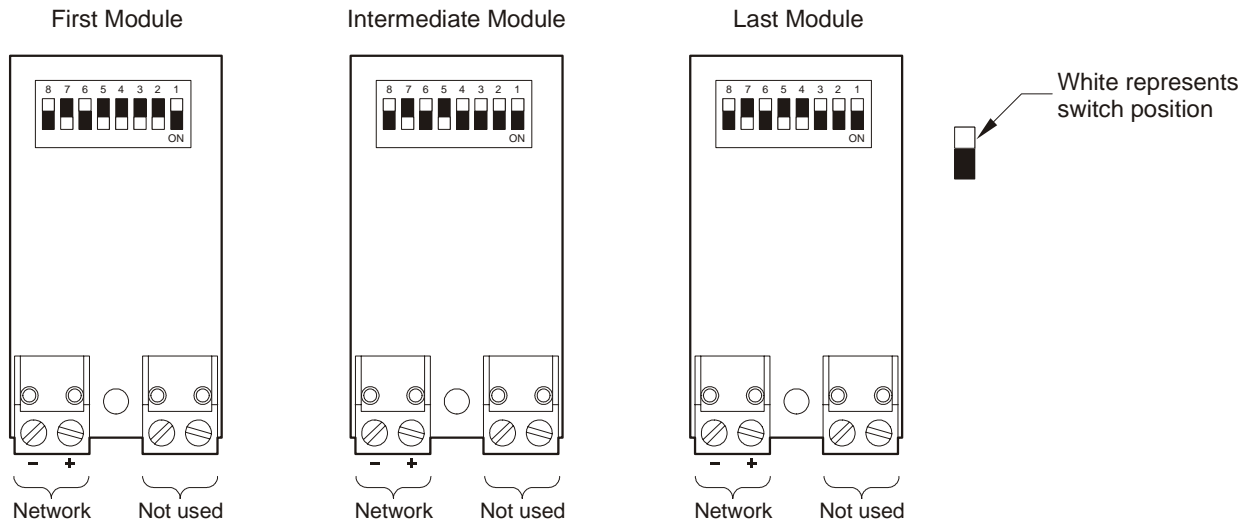

**Figure 11 - RS485 Switch Settings**

**RS422 Mode**

RS422 networks use a 4-wire, point-to-point connection methodology. Set the switches as required and wire the card to the network as shown in Figure 12. It is not necessary to make any connections to the filter board.

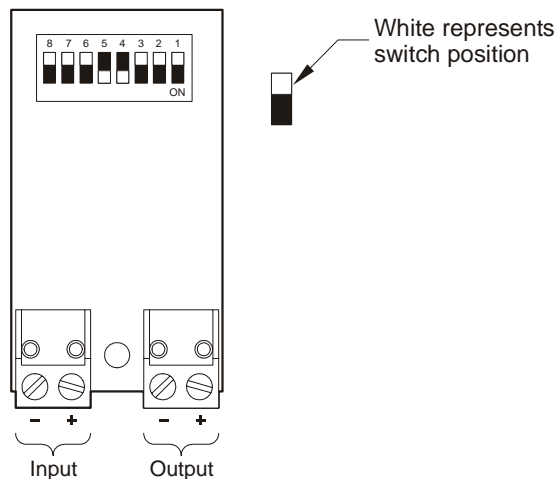

**Figure 12 - RS422 Switch Settings**

**FIBRE-OPTIC NETWORK CARDS**

If a PY-FI7 or PY-FI9 network card is being used, there is no need to make any connections through the filter board, as these network cards are connected to the network directly. For details on to do this, see the installation guide that is provided with the network card.

---

**POWER SUPPLY CONNECTIONS**

---

The boxed variants of the AC receiver include a terminal block mounted on the metal base plate. This external terminal block is used to earth the metal base plate and to connect the factory fitted 12V DC PSU to the mains power supply.

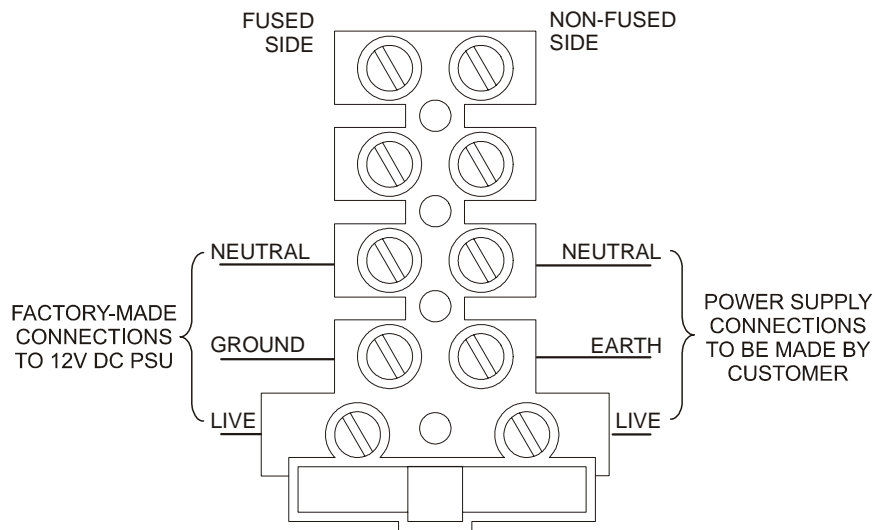

Figure 13 - External Terminal Block

**⚠ WARNING**

- Ensure that the power is switched off before connecting the mains wires.
- The module must be earthed.
- Do not connect additional mains devices to the fused side of the external terminal block.

Connect the Live, Earth and Neutral wires from the mains to Live, Earth and Neutral on the non-fused side of the external terminal block. Switch on the mains power and any other power supplies that are being used—the module now contains live voltages.

When the power is switched on, LED1 lights to indicate the polarity of the 12V DC. If the polarity is correct it will light green, and if it is incorrect, it will light red.

ADDRESSING A RECEIVER WITH THE PYRAMID 2 KEYBOARD

Each receiver that is connected to the Pyramid system must have a unique address called a network address, and an operator with installer privileges can do this using the Pyramid 2 Keyboard.

Configuration of the receiver requires the service button to be pressed on the receiver PCB, and this may be a two man operation if the receiver is located remotely from the keyboard. For this reason, it is easier to address a receiver before it is added to the network, and this can be done using a special mode of the Pyramid keyboard called Self-Bind (also known as Fn 100). Self-binding mode is commonly used when configuring telemetry receivers, or when cameras need to be controlled in a system without a CCTV matrix.

During the self-binding process, the installer can setup the network address, which includes the node ID—the number that is entered to indicate which device is to be controlled (e.g., Camera receiver number 4). Once the network address has been configured, the receiver can be attached to the network and controlled through the Pyramid matrix.

To address a receiver in self-binding mode, follow the steps below:

1. Connect up a Pyramid 2 Keyboard to the telemetry receiver. This can either be connected directly to the receive communications card at the receiver site, or remotely through the Pyramid network in the normal way.
2. Log onto the Pyramid 2 Keyboard using the installer password. The **Installer Logon** screen is displayed.
3. Press the **Function 100** soft-key. The **Direct Access** screen is displayed.
4. Press the **Receiver** soft-key.
5. Press the **Rx Utilities** screen key.
6. Press the **Unit Address Type** soft-key.  
The **Addressing** screen is displayed.
7. Press the **Receiver Address** soft-key. The keyboard LCD displays a message asking the operator to press the service pin.

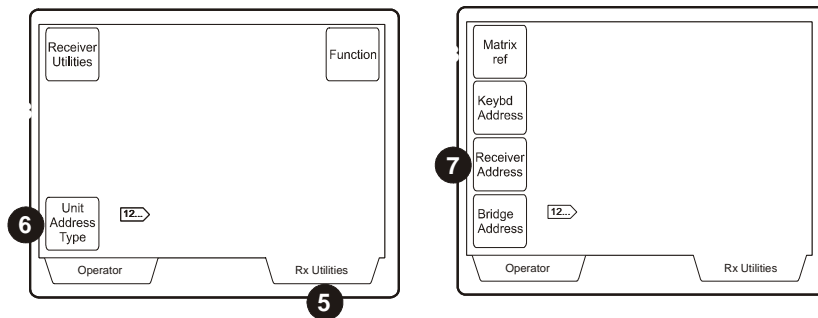

Figure 14 - Addressing a Receiver

8. So that the keyboard can identify the receiver, press its service pin. On the AC receiver, the service pin is located on the PCB as two pins to be shorted (see Figure 2).  
When the service pin is pressed, the receiver's neuron ID is transmitted to all other devices on the Pyramid network. The neuron ID is a unique identifier which is used to establish communication between the receiver and all other devices. Once the receiver has been identified by the network, it can be assigned a node ID.
9. The keyboard LCD displays a message asking the operator to enter the new node ID. The node ID is the visible part of a network address, as it is the number that an operator enters on a keyboard to indicate the device that is to be controlled (e.g., Camera receiver number 3).  
Use the number keys to enter the node ID.
10. Press the **Receiver Address** soft-key again to confirm the node ID.  
The keyboard LCD displays a message confirming the address.

---

**ADDRESSING A RECEIVER WITH THE MK1 KEYBOARD**

---

A receiver can also be addressed using the Pyramid Mk1 Keyboard. Follow the steps below:

1. Connect up a Pyramid Mk 1 Keyboard to the telemetry receiver. This can either be connected directly to the receive communications card at the receiver site, or remotely through the Pyramid network in the normal way.
2. Using the keyboard, insert the Installers Card and log on with the PIN number 1892.
3. Press the key sequence "100" and then the **Function** key.  
The left hand side of the keyboard display will show "Fn 0100" to indicate that self binding mode has been invoked.
4. Repeatedly press the **List Down** key, until the LCD display shows the option "Replace RX".
5. Once this option is displayed, select soft key number 1 marked "Yes".

At this point, the keyboard is now waiting for the receiver to identify itself using the service PIN.

6. Momentarily short out the service PIN jumper on the receiver PCB (see figure 2).  
The receiver neuron ID is transmitted onto the network, and the keyboard display will show the text "Receiver Identified".
7. Type in the node ID you require this receiver to be configured to, and then press the **Camera Select** key.  
After a short delay, the keyboard will then display the message "Subnet Node Calculated".
8. After 10 seconds, the keyboard will then log itself out automatically.
9. Repeat steps 1-3 to log back on to the keyboard and go into self-bind mode.
10. Select a camera in the normal way by typing in the node ID and then pressing the **Camera Select** key.
11. Move the joystick. The PTZ will move, and the standard receiver screen will be displayed on the keyboard.

**Troubleshooting**

**Q** I pressed the service PIN on the receiver, but the keyboard did not show the "Receiver Identified" message.

**A** No data is coming through, check out the data cabling between the receiver and the keyboard.

**Q** I got to stage 7, but the Subnet Node Calculated message remained on the keyboard screen and the keyboard did not log off.

**A** Data is only being transmitted in one direction. Check to see if the data cable has been connected to the correct side of the communications card, or that one side of the twisted pair has become disconnected.

**Note**

The AC receiver can also be addressed and installed using the Pyramid Installation Tool. See the **Pyramid Installation Tool Operating Manual** for more details.

---

**SETTING RECEIVER CONFIGURATION WITH THE PYRAMID 2 KEYBOARD**

---

After a receiver has been addressed, the Pyramid 2 Keyboard can be used to specify the configuration of the receiver remotely via the Pyramid network.

To set the configuration of a receiver, follow the steps below:

1. Enter the keyboard menu system. See the **Pyramid 2 Keyboard Operating Manual** for more details.
2. Select a monitor by entering a number and pressing the **Monitor** key.
3. Enter the number of the receiver that is to be configured and press the **Camera** key.
4. Press the **Utility Menu** screen key.
5. Press the **Receiver Utilities** soft-key.
6. Press the **Rx Config** soft-key. The **Receiver Configuration** screen is displayed.
7. Some Pan/Tilt units are capable of continuous rotation (360°). A small gap can exist in the feedback potentiometer, and this gap is known as the dead band. If a continuous rotation Pan/Tilt head is being used, press the **Non-Cont** soft-key, so that the receiver is configured for a continuous rotation Pan/Tilt unit. The text on the soft-key changes to **Cont**.  
The default setting is to leave the soft-key displaying the text **Non-Cont** (i.e., non-continuous Pan/Tilt head operation).
8. Receivers are supplied with feedback potentiometers enabled. If there are no feedback inputs to the receiver, the manual operation of the Pan/Tilt unit will be affected (e.g., the pan and tilt controls will only operate in one direction), since the feedback inputs are used as a constant check for end stops. If this is the case, disable the feedback potentiometers to correct the problem and enable manual operation. To do this, press the **F/B** soft-key, so that the text changes to **No F/B**.  
The default setting is to leave the soft-key displaying the text **F/B** (i.e., feedback potentiometers enabled).
9. In some cases, zoom lenses have three wire control of zoom and focus functions (i.e., Ground, Zoom +/-, Focus +/-) rather than the usual four wire control. If this is the case, the receiver needs to be configured for the use of a 3-wire lens, so that it carries out the zoom operation first followed by the focus operation on preset recall. To do this, press the **3 Wire Lens** soft-key.  
The default setting is to leave the **3 Wire Lens** soft-key off (i.e., in four wire control).

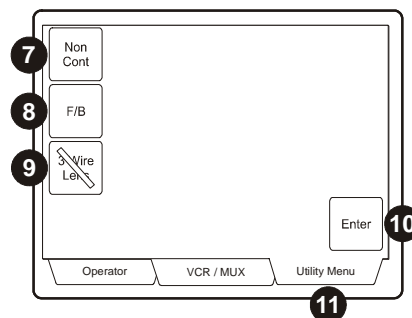

**Figure 15 - Receiver Configuration**

10. Press the **Enter** soft-key to confirm the selection and to send the information to the receiver.
11. Press the **Utility Menu** screen key to leave the **Receiver Configuration** screen.

### △ CAUTION

If the Pan/Tilt head connected to the receiver is not fitted with potentiometers, the F/B function must be disabled at step 8. If this is not done, the pan and tilt operations will only work in one direction. If a Pan/Tilt head is fitted with potentiometers, ensure that mechanical limit stops are set, and then press the test button on the receiver PCB. This will ensure that the potentiometer directions are learnt correctly.



---

**SETTING RECEIVER CONFIGURATION WITH THE MK1 KEYBOARD**

---

The Pyramid Mk1 Keyboard can also be used to specify the receiver configuration. Follow the steps below:

1. Log on using an installers card (Use Fn 100 if the receiver is not connected to a matrix).
2. Select a valid monitor, and then enter the number of the receiver that is to be configured.
3. Press the **List Up** key twice to select "Change Rx Config".
4. Select the **Yes** soft key.
5. The LCD displays the message "Rx has feedback pots". Press the **Yes** or **No** soft key to indicate whether the receiver is connected to feedback potentiometers.
6. To determine whether the receiver is connected to a continuous rotation head, the LCD displays the message "Rx is cont rotate head". Press the **Yes** or **No** soft key.
7. The LCD displays the message "Rx has 3 wire lens" Press the **Yes** or **No** soft key to indicate whether the receiver is using a 3-wire lens.

The receiver has now been configured, and the keyboard will return to the initial display.

**△ CAUTION**

**If the Pan/Tilt head connected to the receiver is not fitted with potentiometers, the feedback pots function must be disabled at step 5. If this is not done, the pan and tilt operations will only work in one direction. If a Pan/Tilt head is fitted with potentiometers, ensure that mechanical limit stops are set, and then press the test button on the receiver PCB. This will ensure that the potentiometer directions are learnt correctly.**

---

**RECEIVER PROGRAMMING**

---

The Pyramid 2 Keyboard can also be used to carry out more advanced receiver programming (e.g., presets, privacy zones, limit stops, random patrols). For more details on how to do this, see the **Pyramid 2 Keyboard Operating Manual**. A copy of the manual is supplied with the Pyramid 2 Keyboard, and can also be obtained from the Baxall website at [www.baxall.com](http://www.baxall.com), or from Baxall Technical Support.

Basic receiver programming can also be achieved using the Mk1 Keyboard. Instructions on how to do this can be obtained from Baxall.

---

**TESTING**

---

Once the receiver has been addressed and configured, an on board test procedure can be activated which steps through outputs in the sequence shown in the table below. The test procedure also allows the receiver to detect the feedback polarity for the Pan/Tilt head and lens.

The test procedure runs when the test button is pressed with an appropriate tool (Figure 2). The test takes 57 seconds.

**⚠ WARNING**

- The AC receiver PCB now contains live voltages.
- Before running the test procedure, fit the Pan/Tilt head in its intended position and ensure that it cannot collide with anything or stretch any cables. Electrical and mechanical limit stops should be set to prevent such events. Electrical limit stops can be set using the Pyramid 2 Keyboard—consult the Pyramid 2 Keyboard Operating Manual for more details.

Step	Action	Time	Step	Action	Time
1	Right and Down	5s	13	Pause	2s
2	Pause	2s	14	Zoom Out	3s
3	Pan Left	3s	15	Zoom In	3s
4	Pause	1s	16	Pause	2s
5	Pan Right	3s	17	Iris Close	3s
6	Pause	2s	18	Iris Open	3s
7	Tilt Up	3s	19	Pause	2s
8	Pause	1s	20	AUX 1	2s
9	Tilt Down	3s	21	AUX 2	2s
10	Pause	2s	22	AUX 3	2s
11	Focus Near	3s	23	AUX 4	2s
12	Focus Far	3s	24	Exit	

---

**REPLACING THE LID**

---

Once the necessary connections have been made and the receiver has been tested and addressed, refit the lid securely to prevent unauthorised access. To do this, tighten the four securing screws with an appropriate tool until they cannot be undone by hand. Do not exceed a torque of 4 Nm.

---

**CHANGING THE FUSE**

---

The fuse holder (see Figure 2) contains a 10A A/S fuse for protecting the relay outputs.

To replace the fuse, switch off all power to the module, turn the top anti-clockwise using an appropriate tool, change the fuse and replace the top.

**Usage**

- Fixed speed pan and tilt control receiver that can be connected to a PTZ camera within the Pyramid system that has an AC Pan/Tilt head. Once fitted, the unit will drive a PTZ head and up to four auxiliary functions (e.g., wipers, lights). The receiver can also be programmed remotely with privacy zones, limit stops, random patrols, and 128 presets.

**Features**

- Fixed speed outputs for 240V AC pan and tilt units
- All connections (except CON6, LIVE and NEUTRAL) via removable screw terminal blocks
- Built in or external anti-tamper switch
- Service pin, barcode and test button included for ease of installation
- Can be installed using Pyramid Installation Tool
- Pan, tilt, zoom, focus and iris control, 10V DC (max 100mA)
- Up to 128 programmable presets
- Random patrol, privacy zones and electronic end stop functions
- Video gain and lift to compensate for long cable runs
- Four auxiliary functions

**Network**

- One network port, to which PY-FTT, PY-COM, PY-485, PY-422, PY-FI7 or PY-FI9 network cards can be fitted. Supports FTT10, RS422, RS485 and Fibre networks

**Relays**

- Pan/Tilt head relays
- 4 auxiliary relays for wash, wipe, lamps and camera power
- Relay outputs Max 240 V at 1A
- Fuse 10A Anti-Surge

**Video**

- Via BNC connectors
- Video 1V pk-pk PAL/NTSC
- Max Gain >5dB remotely programmable from the keyboard
- Max Lift >4dB at 4MHz remotely programmable from the keyboard

**Power**

- Board Power 12V DC  $\pm$  10%, 1A class 2
- Relay Power max 240V AC, 10A
- Nominal Consumption 8.5 Watts (12V DC)
- CON2, +5V max 30mA (feedback pots)

**Physical**

- Unit available enclosed in a IP65 weatherproof box or as a PCB only
- Weight of PCB only variants 0.5 kg
- Weight of weatherproof box variants 5 kg
- PCB size 130 x 160 x 40 mm (excluding mounting pillars)
- Weatherproof box size 280 x 280 x 130 mm

**Temperature Specification**

- Operational temperature limits of -10°C to +50°C at 10% to 80% relative humidity (non-condensing)
- Storage temperature limits of -20°C to +60°C at 10% to 95% relative humidity (non-condensing)

**Baxall Limited**, Stockport, England. Visit our Web site: <http://www.baxall.com>

Baxall Limited reserve the right to make changes to the product and specification of the product without prior notice to the customer.